

No.	REVISIONS	DATE	DRAWN	APP.
△				
△				

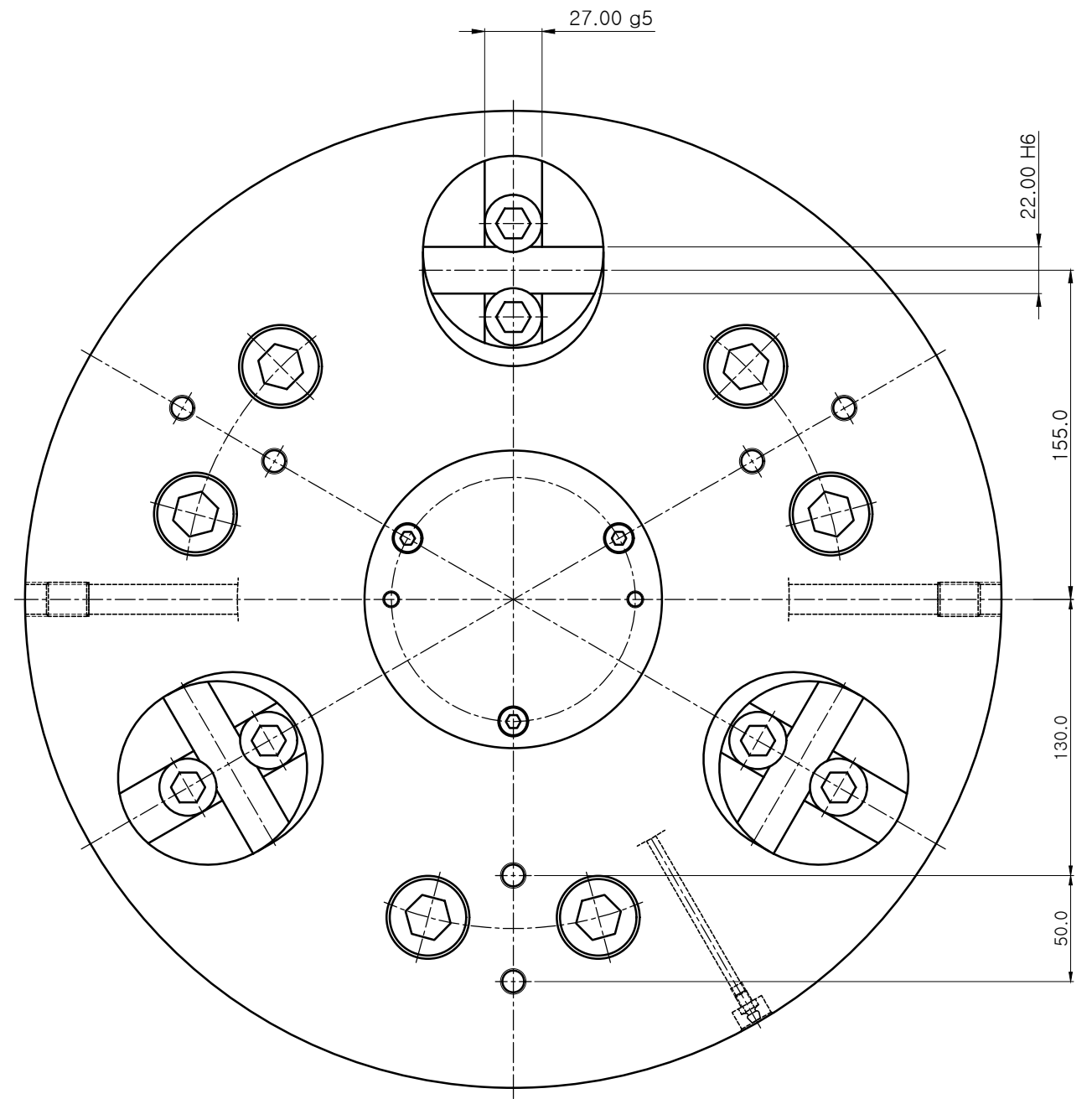

CHUCK SPEC.	
CHUCK SPEC.	DDL-18
PLUNGER STROKE	25 mm
JAW STROKE	18.2 mm
MAX. INPUT FORCE	5,500 kgf
CLAMPING FORCE	9,000 kgf
MAX. SPEED	1,200 rpm
MOMENT OF INERTIAL	11.0kgf.m ²
WEIGHT	185 kg

1	BLANK CHUCK	STD.	DDL-18	1SET	-
NO.	TITLE OF ITEM	MATERIAL	SIZE & SPEC.	QTY	NOTE
	DRAW DOWN CHUCK (DDL-18)		PART NAME	ASSEMBLY DRAWING	
DWG. NO.	DDL-18	AGENCY	-		
CODE NO.	-	USER	-		
		DATE	-		
SCALE	1 : 1	Approved	Checked	Designed	

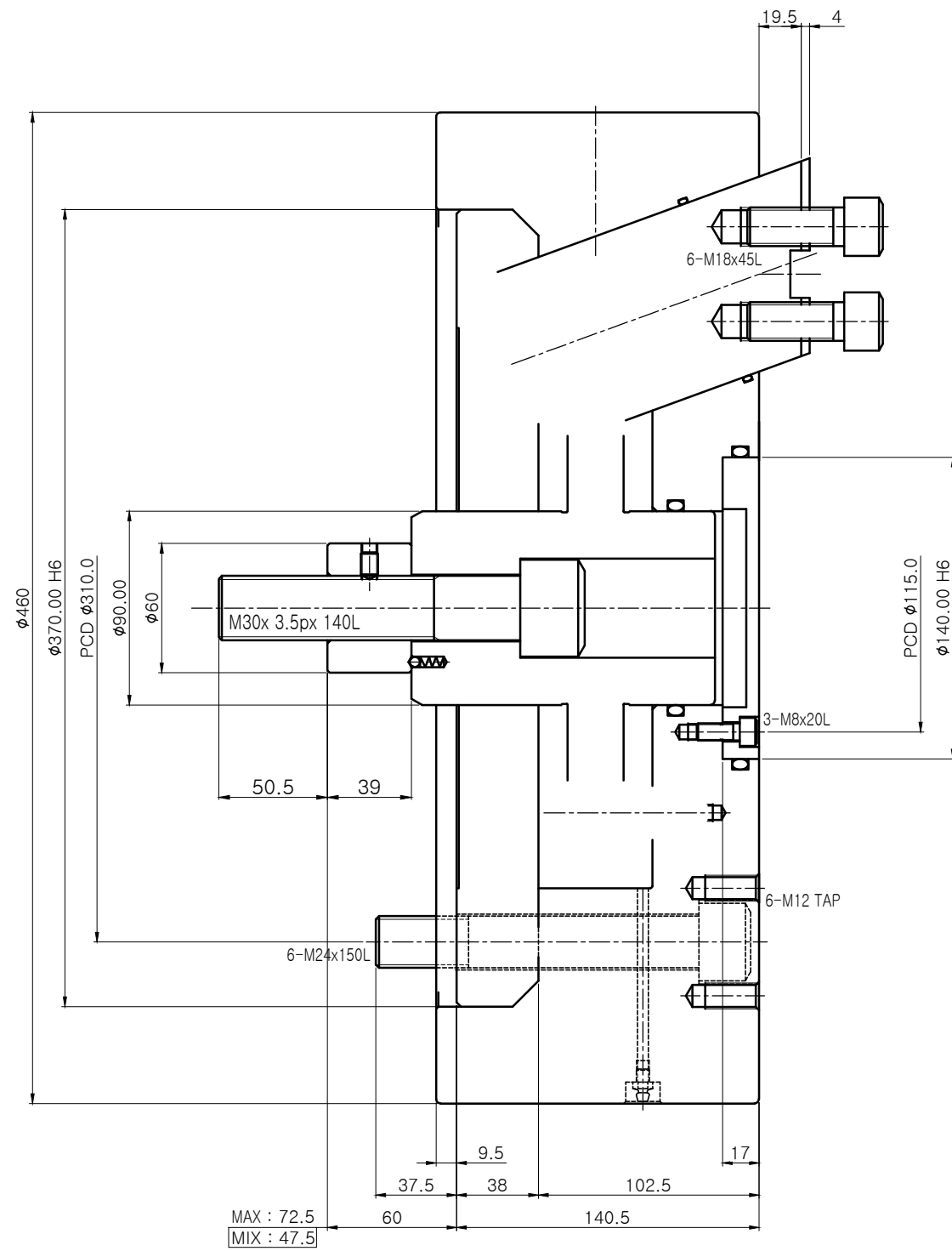