

No.	REVISIONS	DATE	DRAWN	APP.
1				
2				

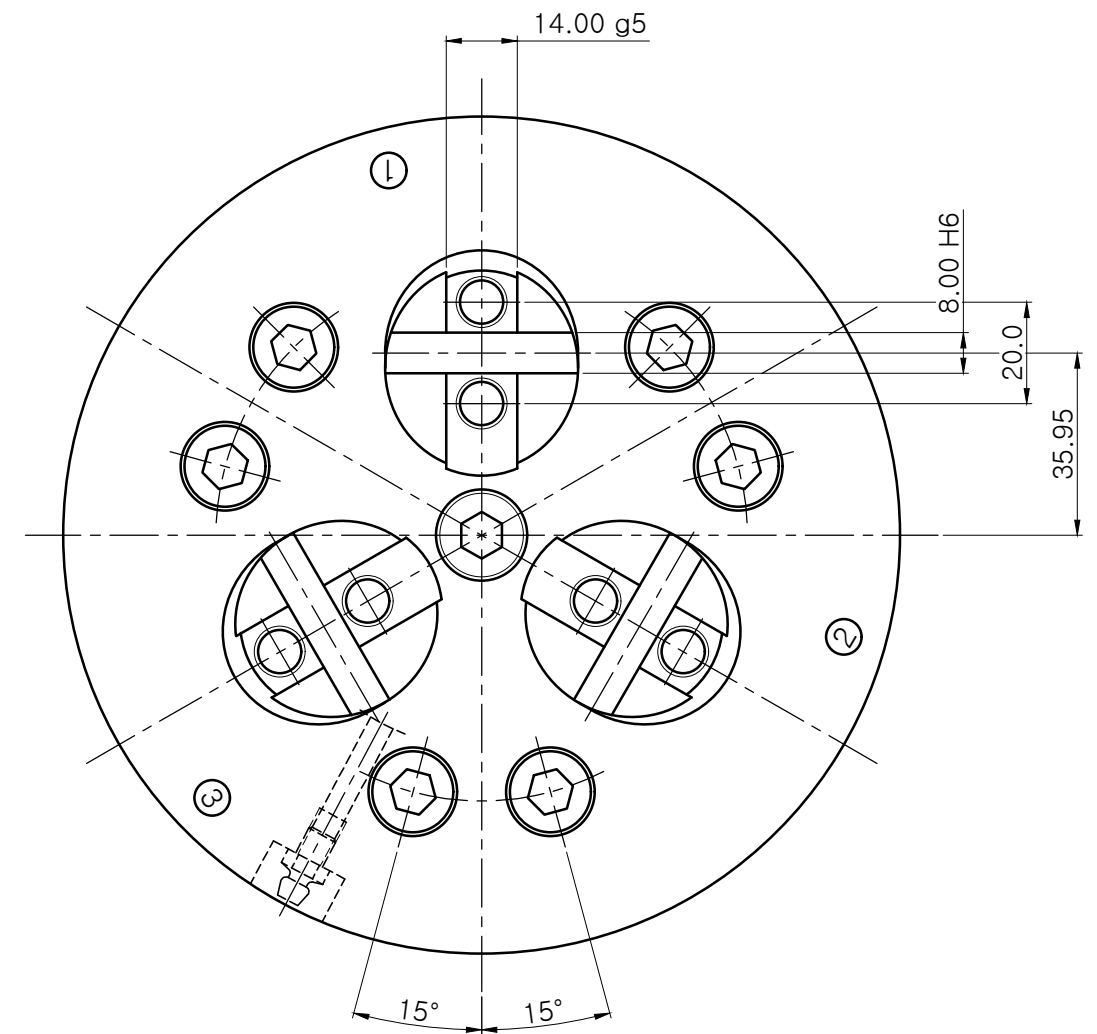

CHUCK SPEC.	
CHUCK SPEC.	DDO-06
PLUNGER STROKE	8 mm
JAW STROKE	5.8 mm
MAX. INPUT FORCE	1,500 kgf
CLAMPING FORCE	2,500 kgf
MAX. SPEED	5,000 rpm
MOMENT OF INERTIAL	0.18kgf.m <sup>2</sup>
WEIGHT	13 kg

01	BLANK CHUCK	STD.	DDO-06	1SET	-			
NO.	TITLE OF ITEM	MATERIAL	SIZE & SPEC.	Q'TY	NOTE			
	DRAW DOWN CHUCK (DDO-06)		PART NAME	ASSEMBLY DRAWING				
DWG. NO.	DDO-06		AGENCY	-				
CODE NO.	-		USER	-				
			DATE	-				
SCALE	1 : 1		<table border="1"> <tr> <td>Approved</td> <td>Checked</td> <td>Designed</td> </tr> </table>			Approved	Checked	Designed
Approved	Checked	Designed						

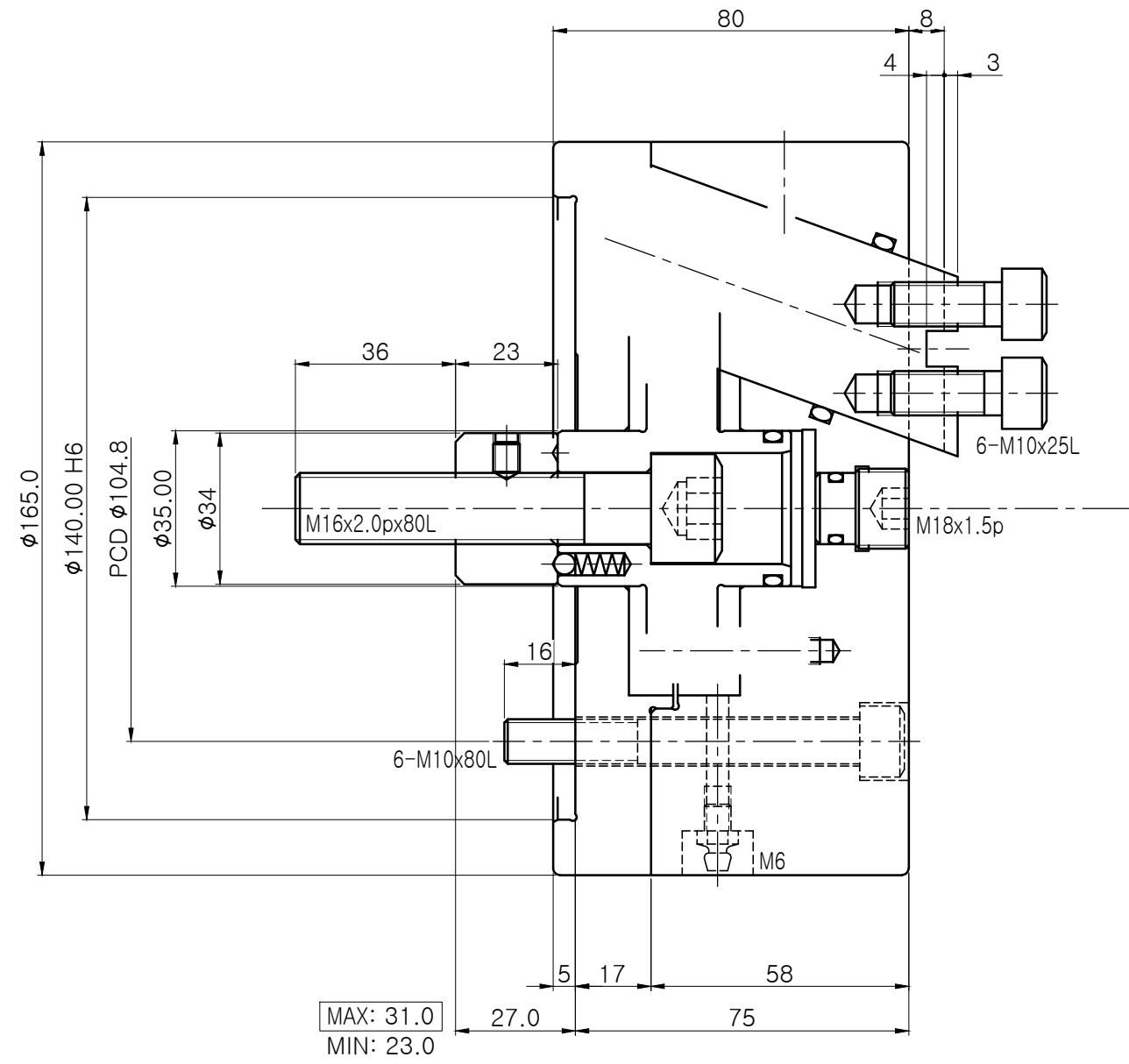