

| No. | REVISIONS | DATE | DRAWN | APP. |
|-----|-----------|------|-------|------|
| ① | | | | |
| ② | | | | |

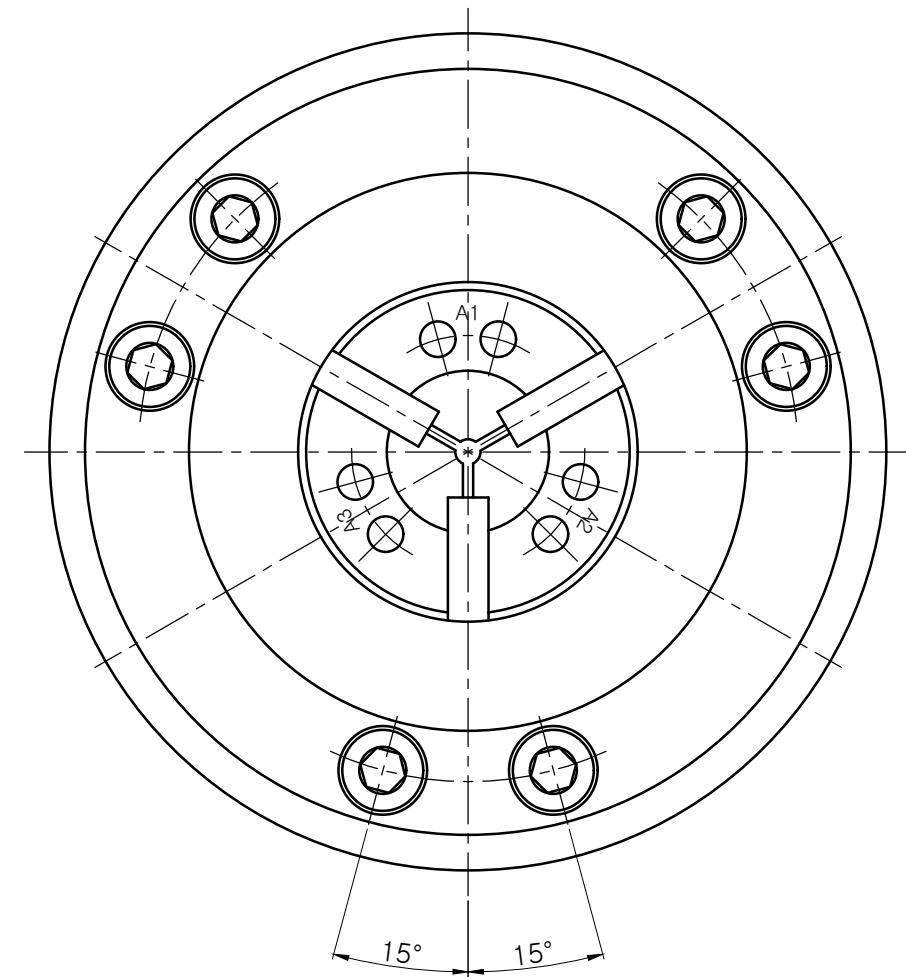
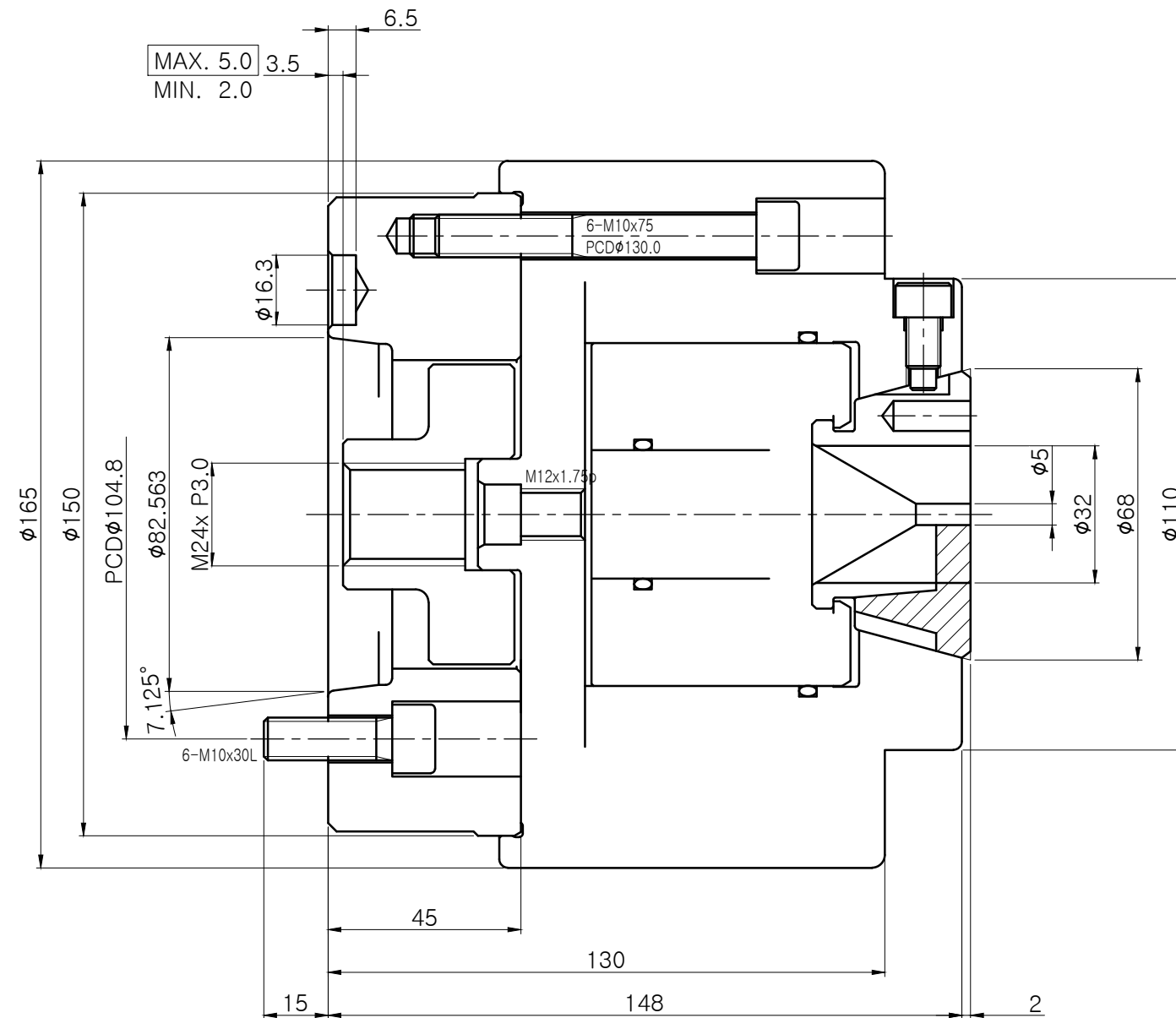

| CHUCK SPEC. | |
|--------------------|----------------------|
| CHUCK SPEC. | COR-32B |
| PLUNGER STROKE | 3 mm |
| JAW STROKE | φ1 mm |
| MAX. INPUT FORCE | 3,200 kgf |
| CLAMPING FORCE | 7,200 kgf |
| MAX. SPEED | 4,500 rpm |
| MOMENT OF INERTIAL | - kgf.m ² |
| WEIGHT | 25 kg |

| | |
|--------------|--------------|
| 표준 파악 범위(mm) | φ5 ~ φ32(mm) |
|--------------|--------------|

| - | CHANGING FIXTURE | STD. | - | - | 주문사양 |
|----------|--------------------------------|----------|--------------|------------------|----------|
| - | COLLET | STD. | - | - | 주문사양 |
| 01 | BLANK CHUCK | STD. | COR-32B | 1SET | - |
| NO. | TITLE OF ITEM | MATERIAL | SIZE & SPEC. | Q'TY | NOTE |
| TITLE | OUTSIDE COLLET CHUCK (COR-32B) | | PART NAME | ASSEMBLY DRAWING | |
| DWG. NO. | COR-32B | | AGENCY | - | |
| CODE NO. | - | | USER | - | |
| | | | DATE | - | |
| SCALE | 1 : 1 | | Approved | Checked | Designed |



| No. | REVISIONS | DATE | DRAWN | APP. |
|-----|-----------|------|-------|------|
| ① | | | | |
| ② | | | | |

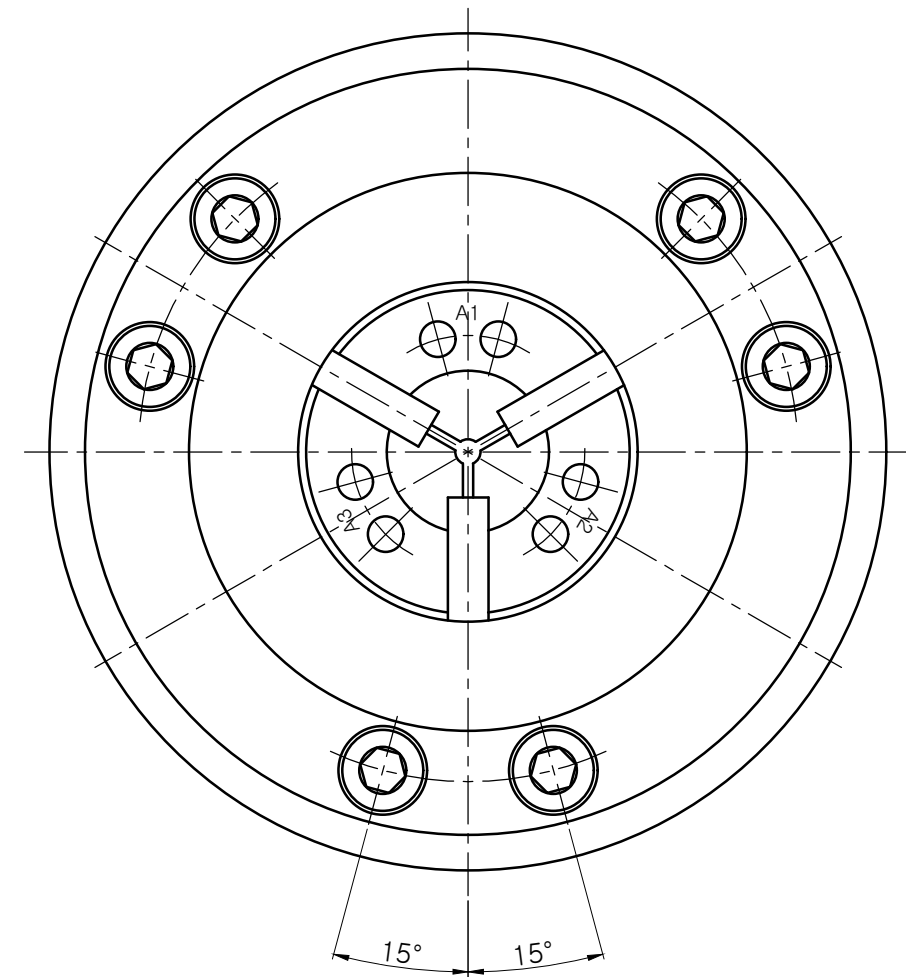
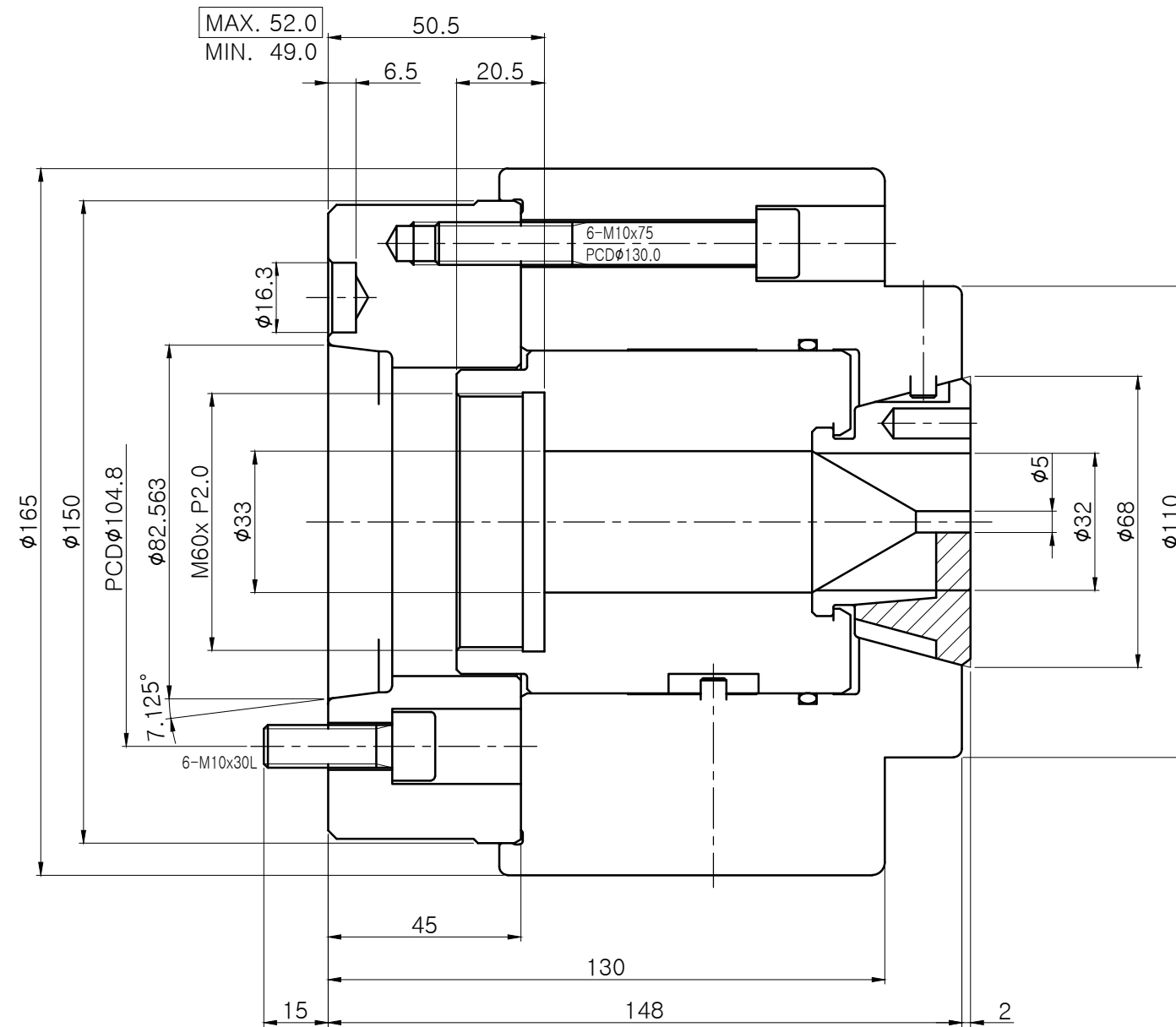

| CHUCK SPEC. | | | |
|--------------------|----------------------|--------------|--------------|
| CHUCK SPEC. | COR-32 | 표준 파악 범위(mm) | φ5 ~ φ32(mm) |
| PLUNGER STROKE | 3 mm | | |
| JAW STROKE | φ1 mm | | |
| MAX. INPUT FORCE | 3,200 kgf | | |
| CLAMPING FORCE | 7,200 kgf | | |
| MAX. SPEED | 4,500 rpm | | |
| MOMENT OF INERTIAL | - kgf.m ² | | |
| WEIGHT | 25 kg | | |

| - | CHANGING FIXTURE | STD. | - | - | 주문사양 |
|-----|------------------|-------------------------------|--------------|-----------|------------------|
| - | COLLET | STD. | - | - | 주문사양 |
| 01 | BLANK CHUCK | STD. | COR-32 | 1SET | - |
| NO. | TITLE OF ITEM | MATERIAL | SIZE & SPEC. | Q'TY | NOTE |
| | TITLE | OUTSIDE COLLET CHUCK (COR-32) | | PART NAME | ASSEMBLY DRAWING |
| | DWG. NO. | COR-32 | | AGENCY | - |
| | CODE NO. | - | | USER | - |
| | | | | DATE | - |
| | SCALE | 1 : 1 | | Approved | Checked |
| | | | | Designed | |

