

No.	REVISIONS	DATE	DRAWN	APP.
①				
②				

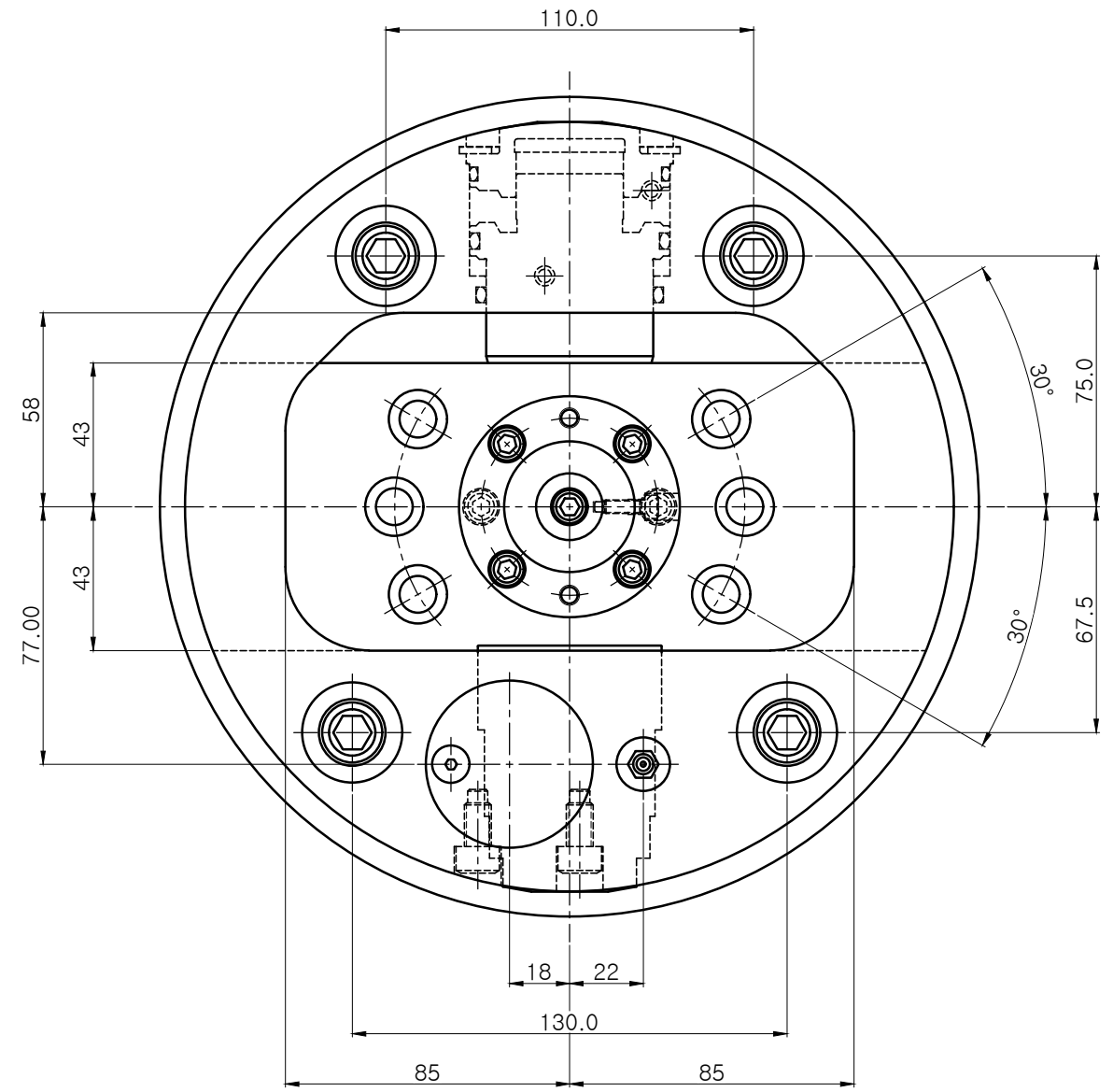

SPECIFICATION	
CLAMP PISTON STROKE	14.5 mm
CLAMP PISTON AREA	28.3 cm ²
최고 회전수	2800 RPM
WEIGHT	29 kgf
적용 CYLINDER	IAHT-230
최대설정 유압력	45 kgf/cm ²

1	BLANK CHUCK	STD.	IAHT-230	1SET	-
NO.	TITLE OF ITEM	MATERIAL	SIZE & SPEC.	Q'TY	NOTE
TITLE	AUTO INDEX CHUCK (IAHT-230)	PART NAME	ASSEMBLY DRAWING		
DWG. NO.	IAHT-230	AGENCY	-		
CODE NO.	-	USER	-		
		DATE	-		
SCALE	1:1	Approved	Checked	Designed	

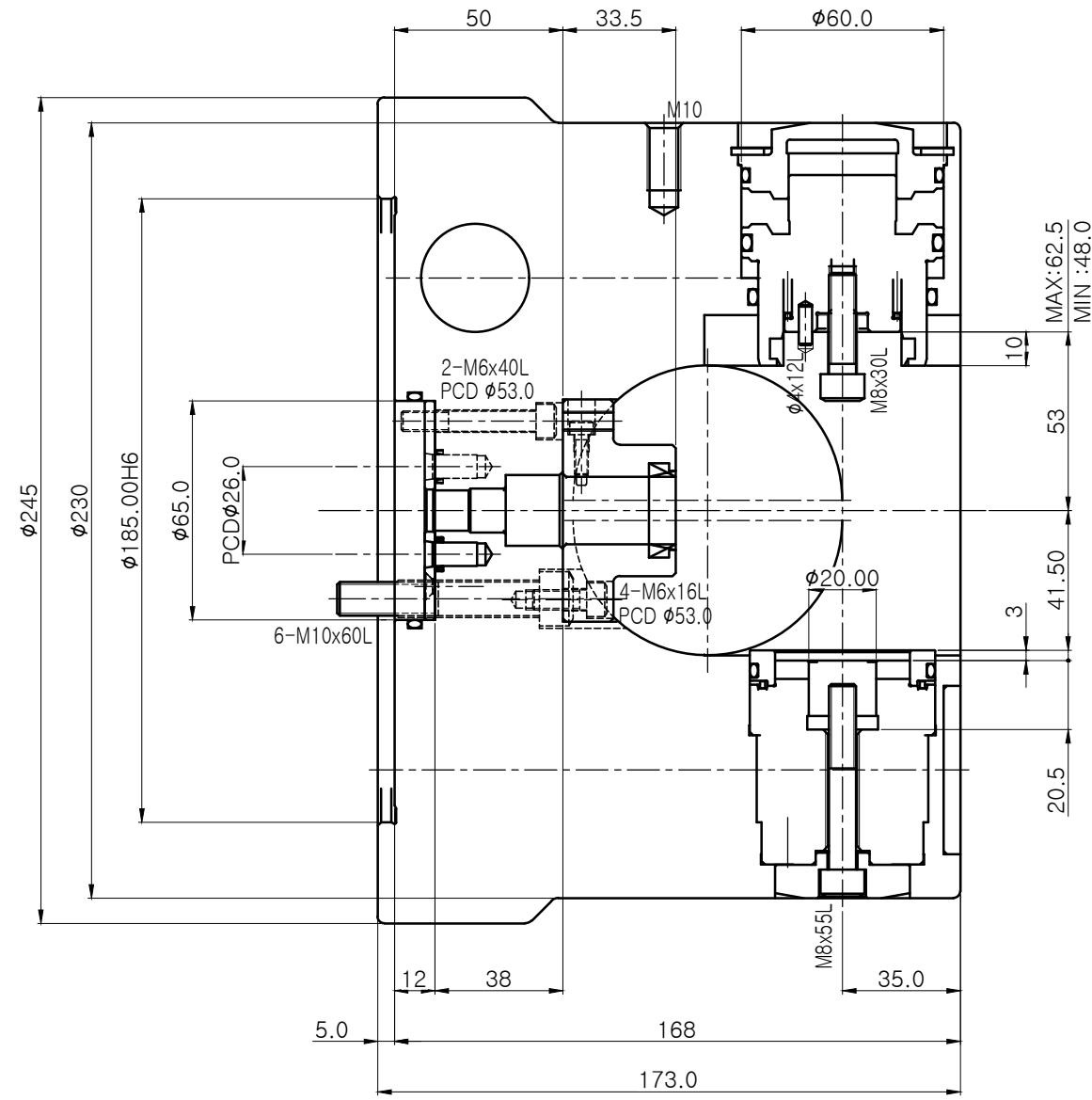