

A0

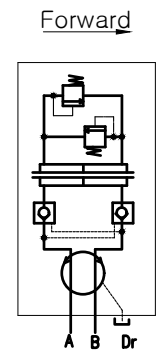
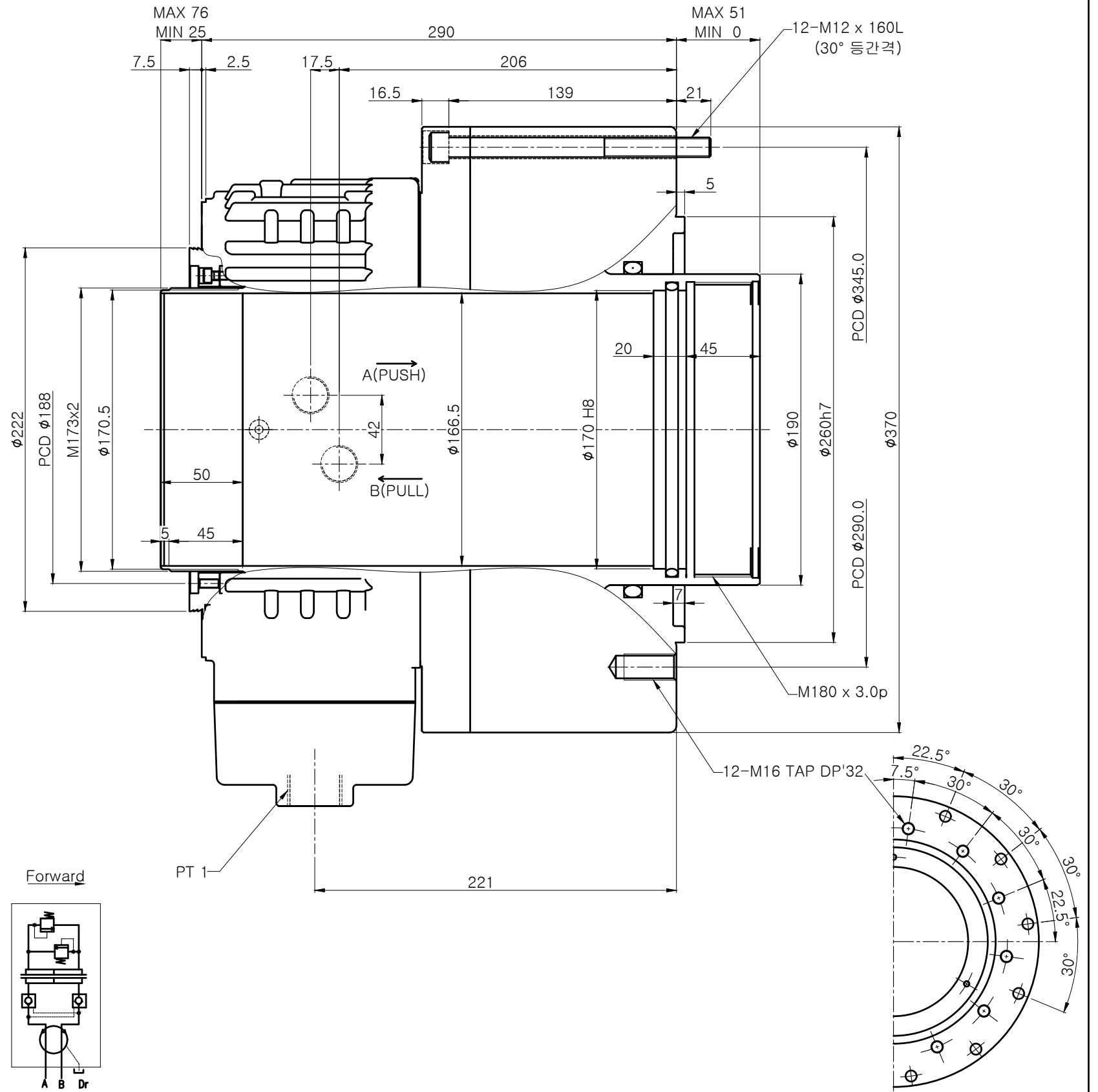
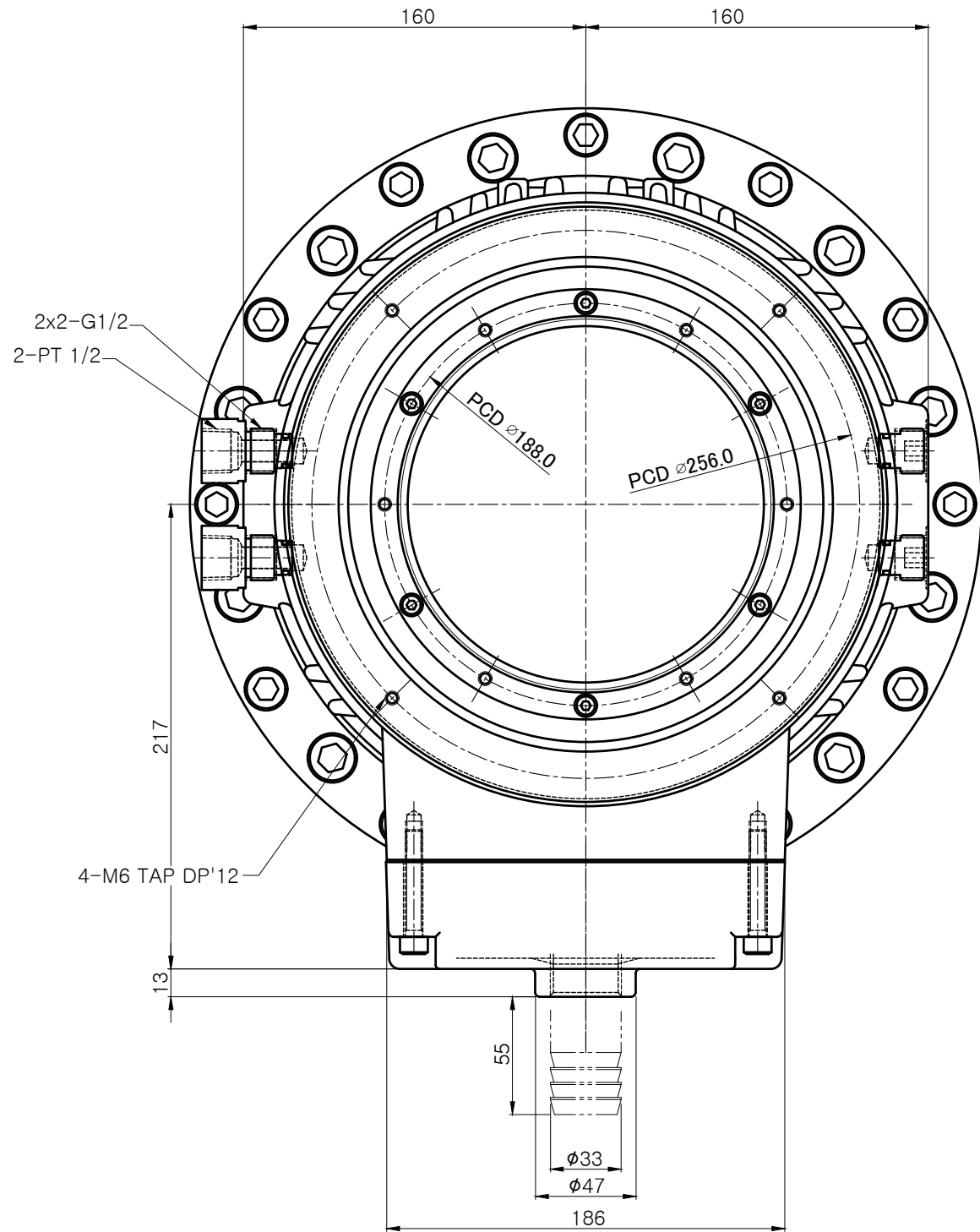

Hydraulic circuit Diagram

전면체결부

SPECIFICATION	
CYLINDER INSIDE DIAMETER	305 mm
PISTON STROKE	51 mm
PISTON THRUST 유압력 3.3MPa (33.6 kgf/cm ²)	PUSH (480cm ³) (15,483 kgf)
	PULL (436cm ³) (14,063 kgf)
최고유압력	3.3 MPa (33.6 kgf/cm ²)
최고회전수	2,000 rpm
WEIGHT	90kg
Moment of Inertia	1.45kg·m ²
TOTAL DRAIN 양 유압력 : 3.0 MPa, 회전수 : 최고회전수 유온 : 50°C (입력부) - 58°C (드레인부) 점도 : ISO.VG.32 (상당), 탱크용량 : 60L	8.4 liter/min

순번	0	규격	SDL-30516	부품명	외형도
도명	SDL-30516 외형도			분류	초고속 중공 유압실린더
도번	SDL-30516-WEB			부서	기술 연구소
투상				날짜	2021. 05. 21
척도	1:1				
	승인	검도	설계		