

LEFT TYPE (좌)

변경 사항				
기호	변경 내용	날짜	수정	승인
△				
△				

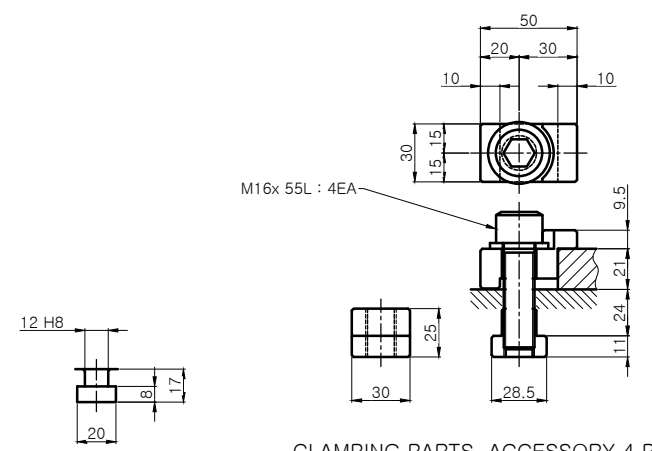
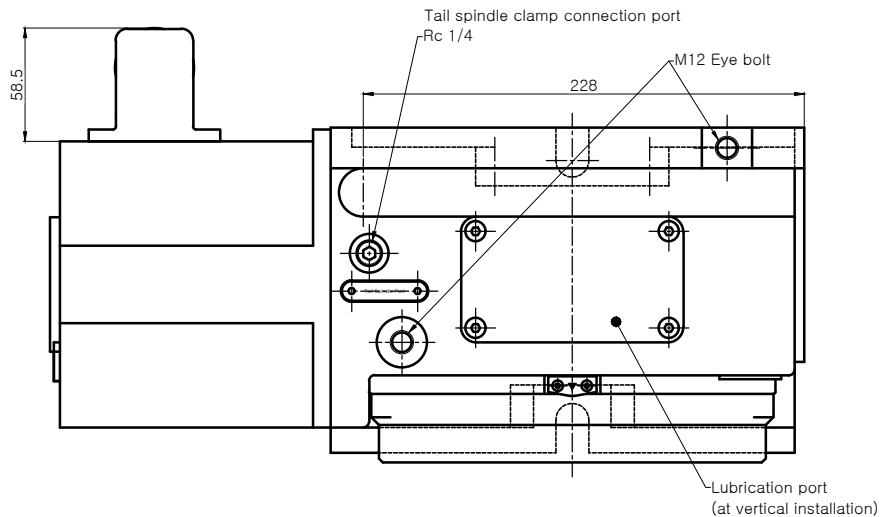

CLAMPING PARTS ACCESSORY 4 PAIR

TABLE T-HOME

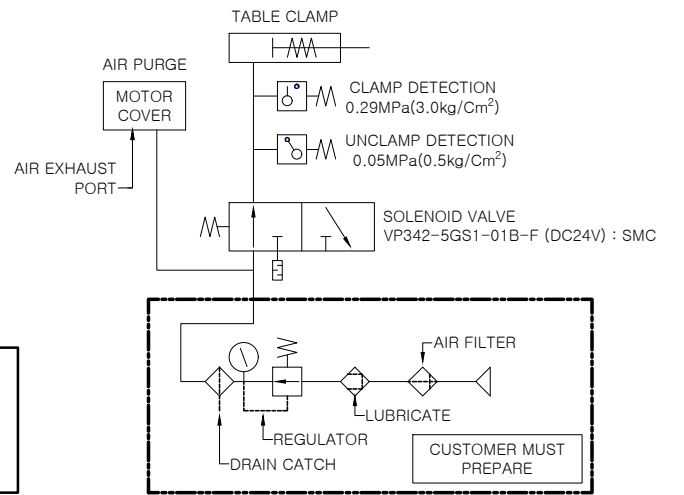
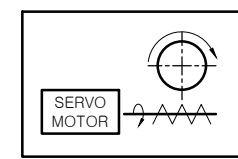
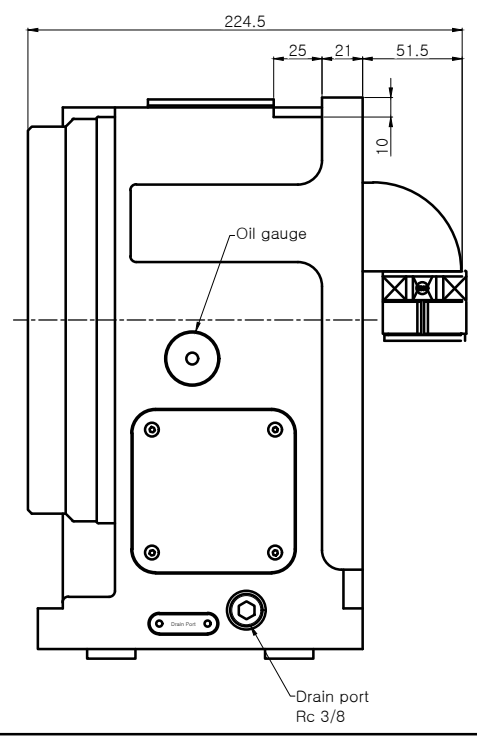
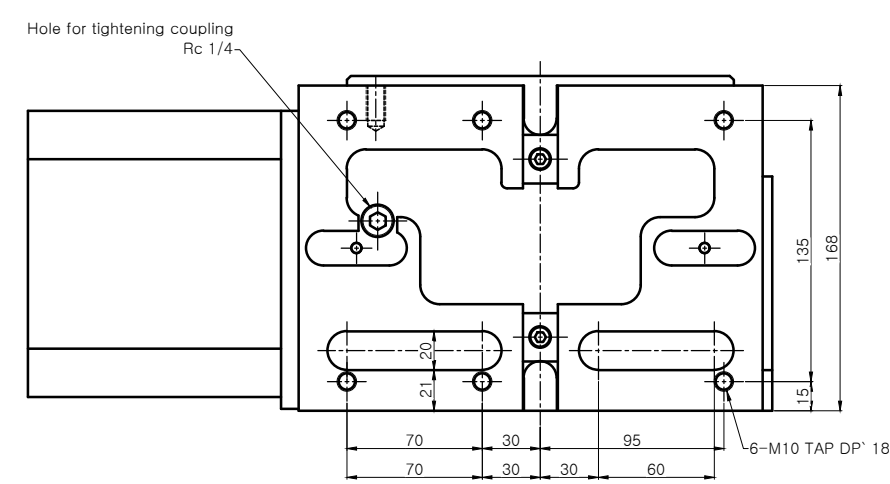
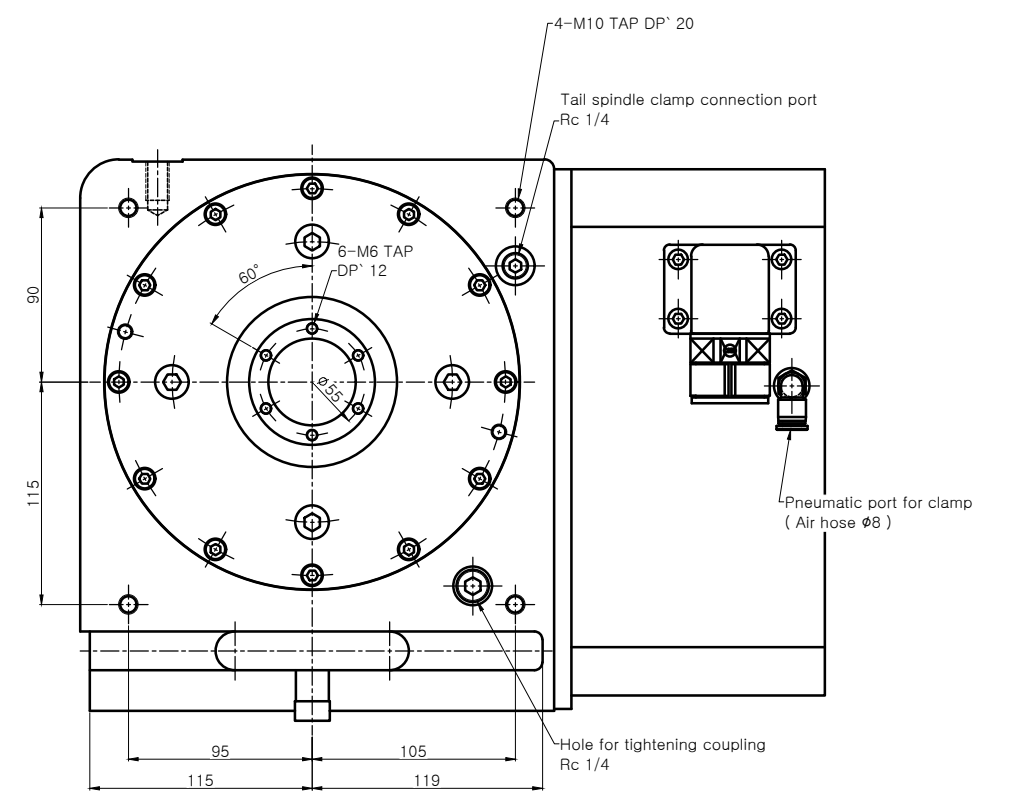
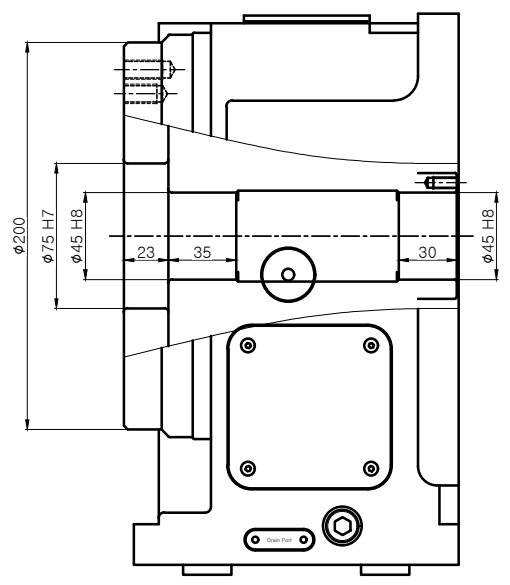
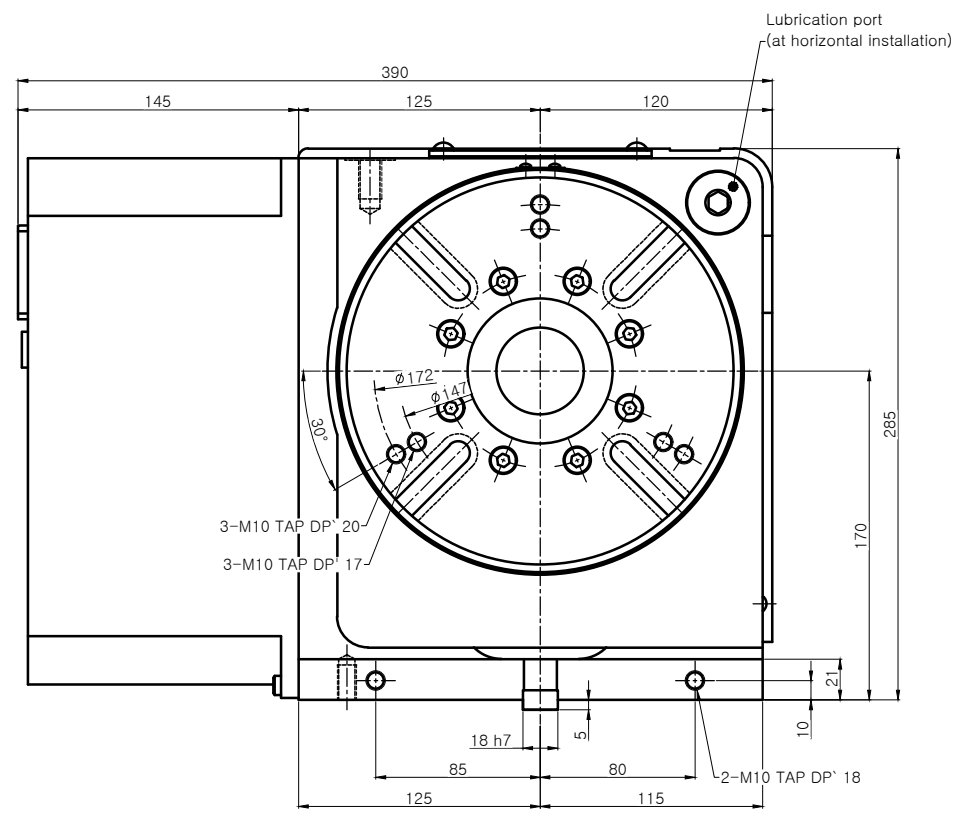
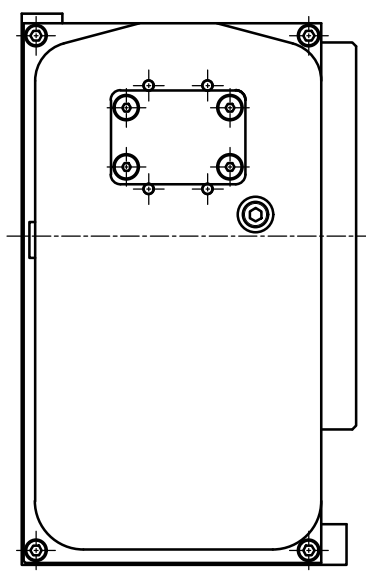

SPECIFICATION	
테이블 직경 Table Diameter	φ200 mm
센터 높이 Center Height	170 mm
테이블 내경 Table Inner Diameter	φ75H7
관통경 Spindle Through Hole Diameter	φ45H8
클램프 방식 Clamp Method	Pneumatic 5 ~ 7 kgf/cm ²
관성 모멘트 Allowable Work Inertia	0.5 kg·m ²
클램프 토크 Clamp Torque	480 N·m
회전 속도 Max. Spindle Speed	33.3 min ⁻¹ (MOTOR MAX 3000 min ⁻¹)
기어비 Gear Ratio	1 / 90
무게 Weight	79 kg
기어 오일 Gear Lubrication	ISO VG #220
허용하중 ALLOWABLE MASS OF WORK	200 kg [HOR.] 100 kg [VER.]

TITLE	Nc Rotary Table	PART NAME	외 형 도
DRG. NO.	S-200LY2-00	USER	-
CODE NO.	S200L-00	DEPARTMENT	Research & Development
		DATE	2010. 08. 13
SCALE	1 : 1	Approved	Checked
		Designed	

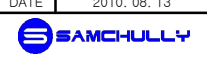

LEFT TYPE (좌)

TABLE 미부착

변경 사항				
기호	변경 내용	날짜	수정	승인
△				
△				

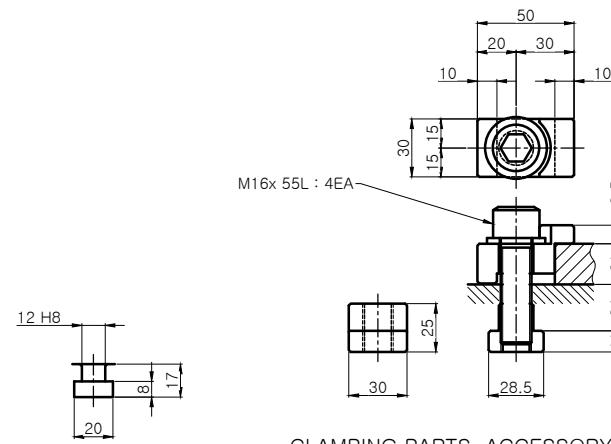
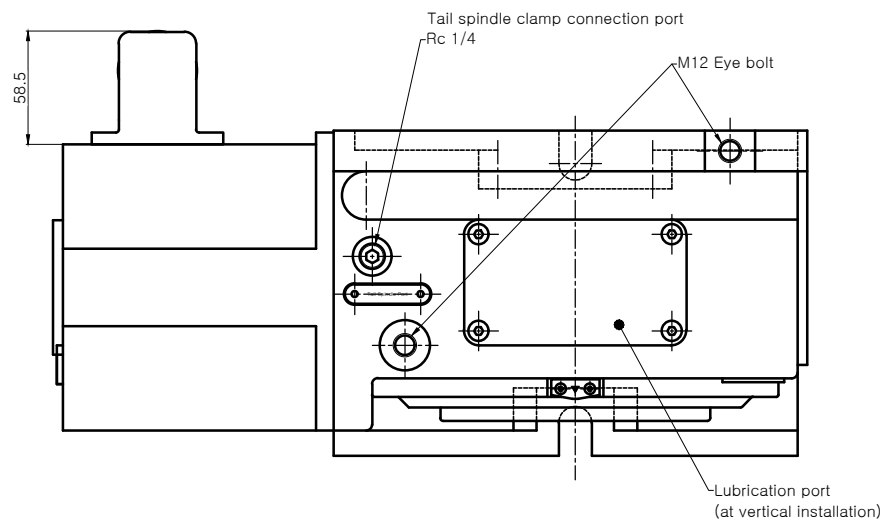
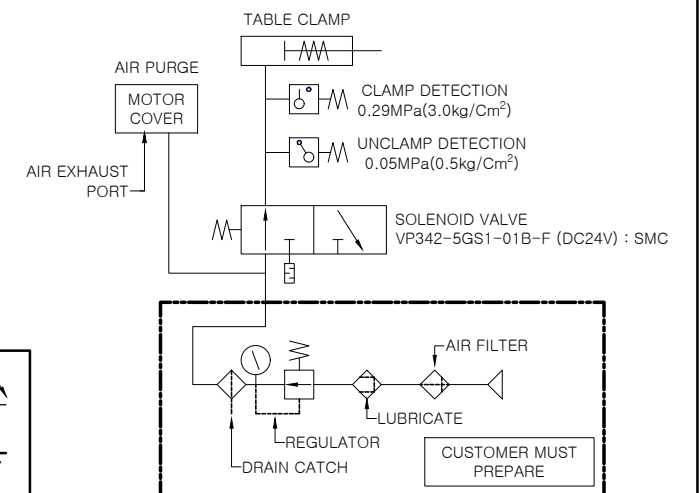
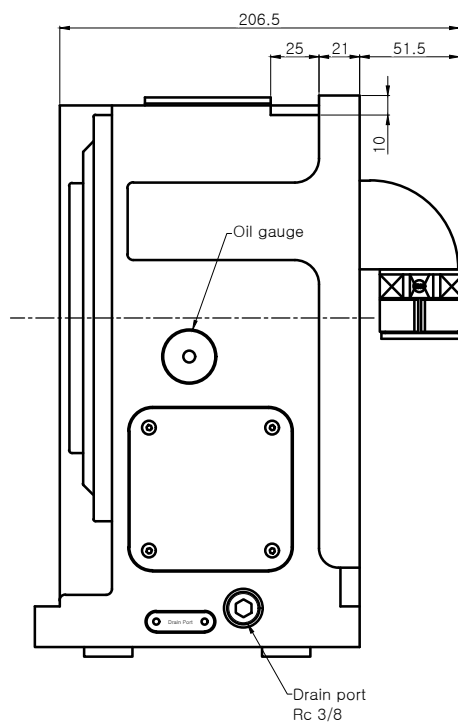
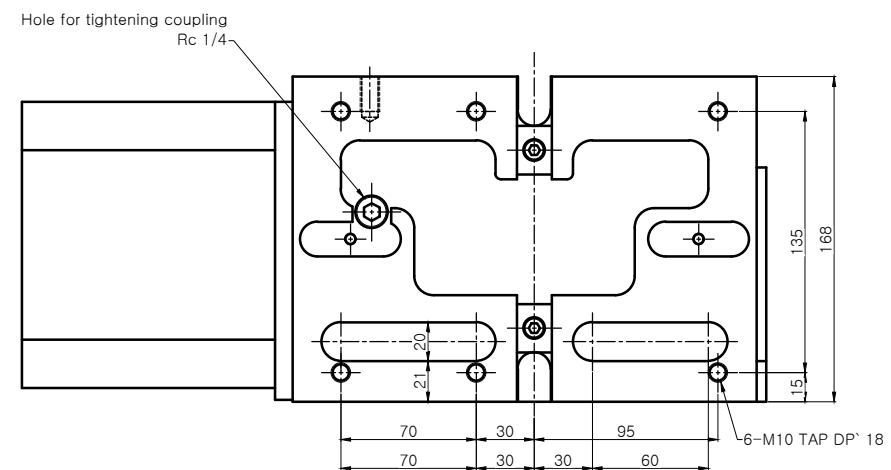
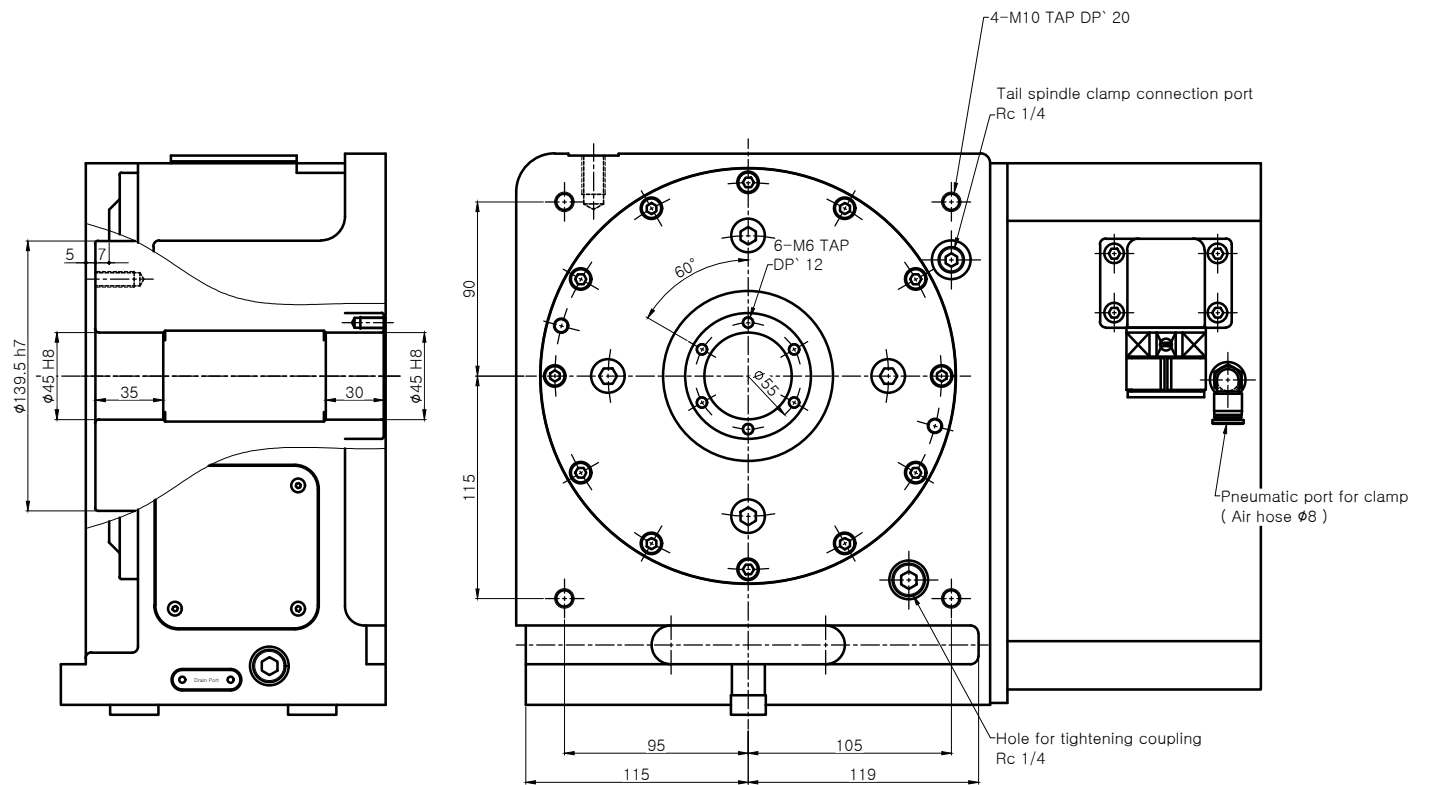
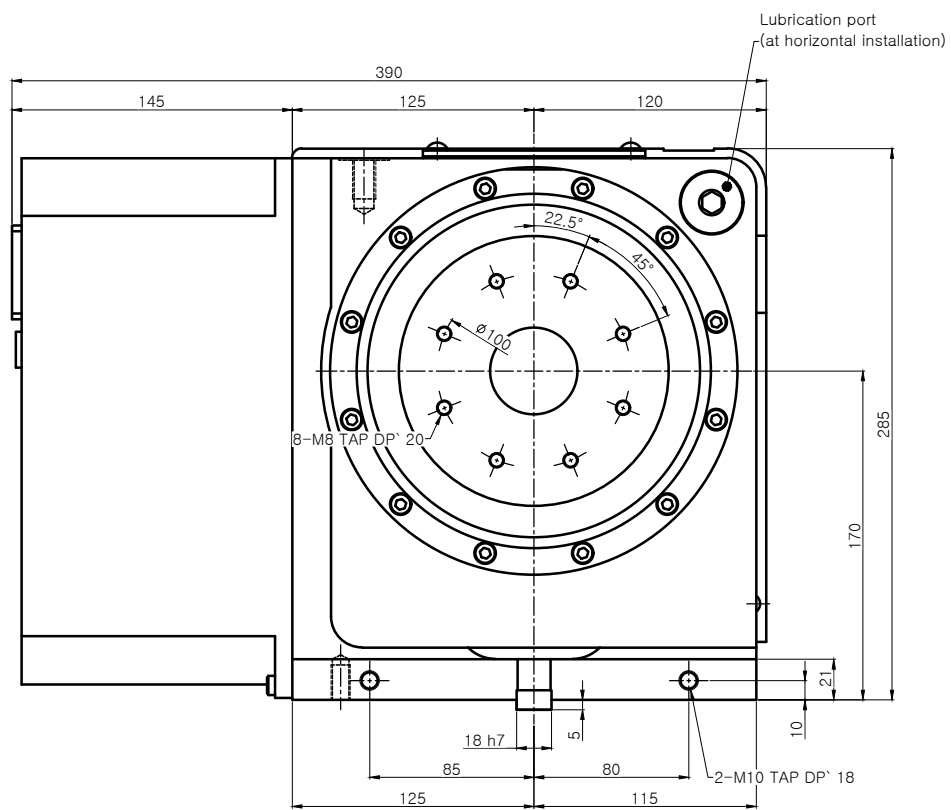
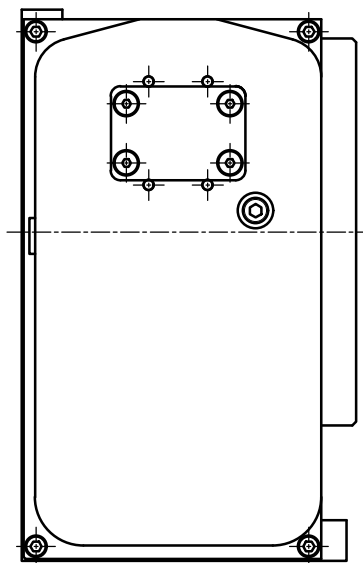

TABLE T-HOME

CLAMPING PARTS ACCESSORY 4 PAIR



SPECIFICATION	
스핀들 직경 Spindle Diameter	φ139.5 mm
센터 높이 Center Height	170 mm
테이블 내경 Table Inner Diameter	-
관통경 Spindle Through Hole Diameter	φ45H8
클램프 방식 Clamp Method	Pneumatic 5 ~ 7 kgf/cm ²
관성 모멘트 Allowable Work Inertia	0.5 kg·m ²
클램프 토크 Clamp Torque	480 N·m
회전 속도 Max. Spindle Speed	33.3 min ⁻¹ (MOTOR MAX. 3000 min ⁻¹)
기어비 Gear Ratio	1 / 90
무게 Weight	79 kg
기어 오일 Gear Lubrication	ISO VG #220
허용하중 ALLOWABLE MASS OF WORK	200 kg [HOR.] 100 kg [VER.]

TITLE	Nc Rotary Table	PART NAME	외 형 도
DRG. NO.	S-200LY2-00	USER	-
CODE NO.	S200L-00	DEPARTMENT	Research & Development
		DATE	2010. 08. 13
SCALE	1 : 1	Approved	Checked
		Designed	

